

THIS DRAWING IS THE PROPERTY OF SUMITOMO HEAVY INDUSTRIES, LTD. (SHI) AND IS CONFIDENTIAL. IT SHALL NOT BE REPRODUCED, NOR USED FOR ANY OTHER PURPOSE, NOR SUBMITTED TO OUTSIDE PARTIES WITHOUT SHI'S PERMISSION.

NO. PIECE FOR SET	DESCRIPTION	MARK	MATERIAL	MASS kg		STANDARD NO.	MATERIAL SPEC.
				FOR ONE	TOTAL		
					26		

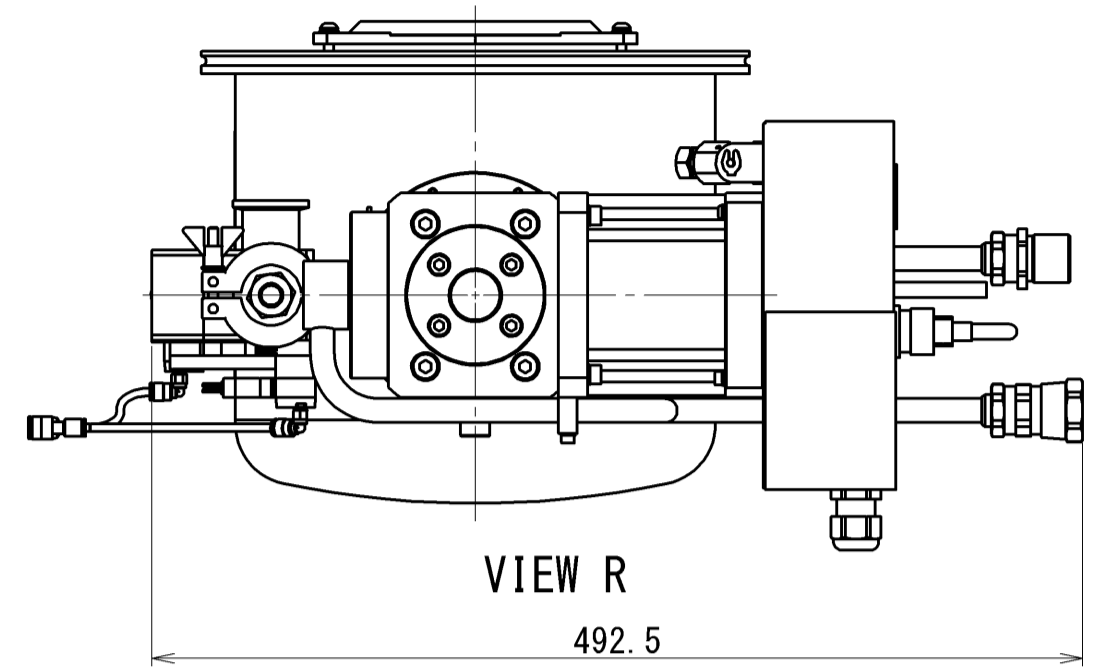
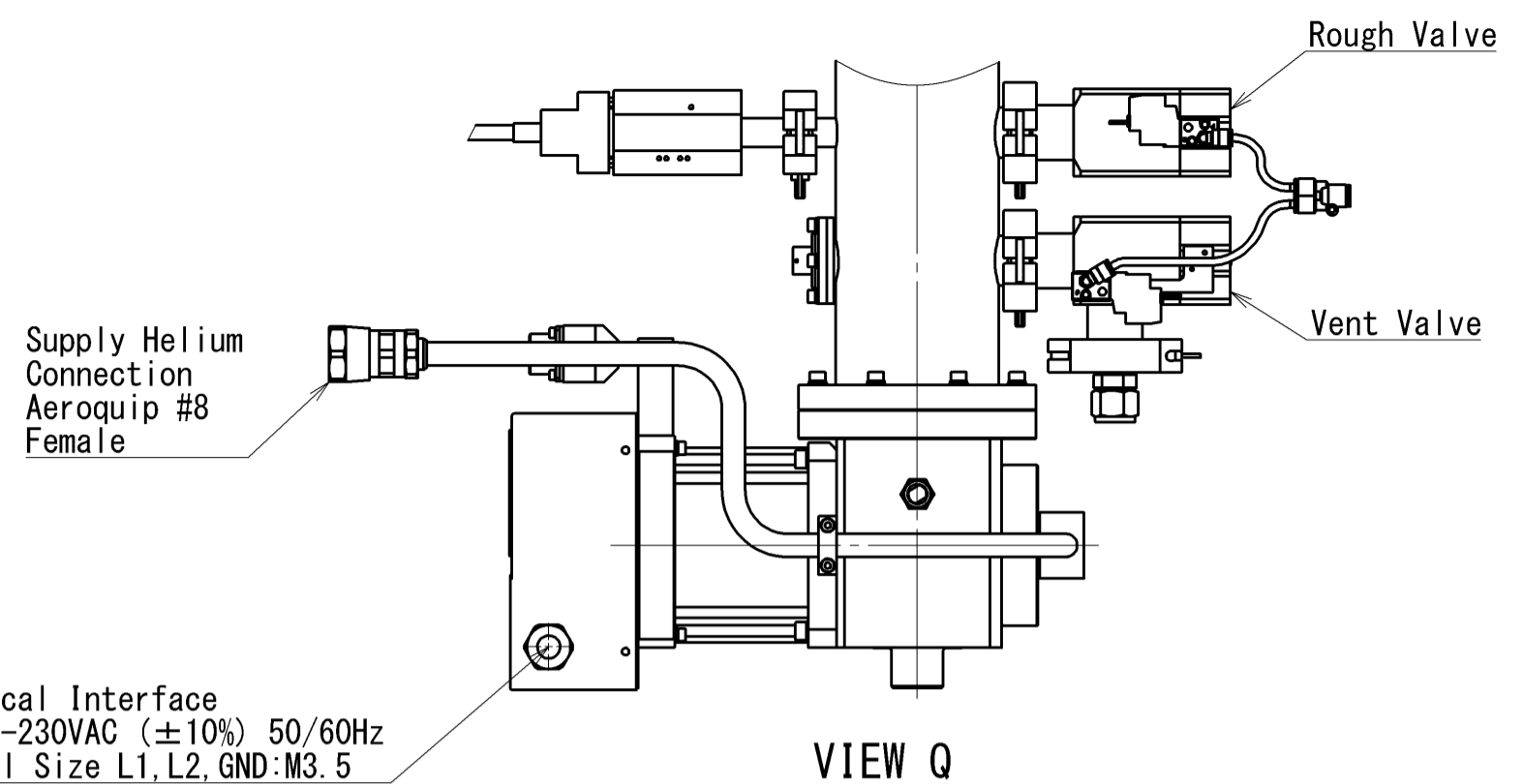

NOTE  
1) CHARGED HELIUM GAS 1.65-1.70MPa.  
2) PART NUMBER PLATE DETAIL.

CRYOPUMP  
KZ-10SCLOA0B3  
Sumitomo Heavy Industries, Ltd.  
MADE IN JAPAN  
SHI PART NO.  
KZ-10SCLOA0B3-0

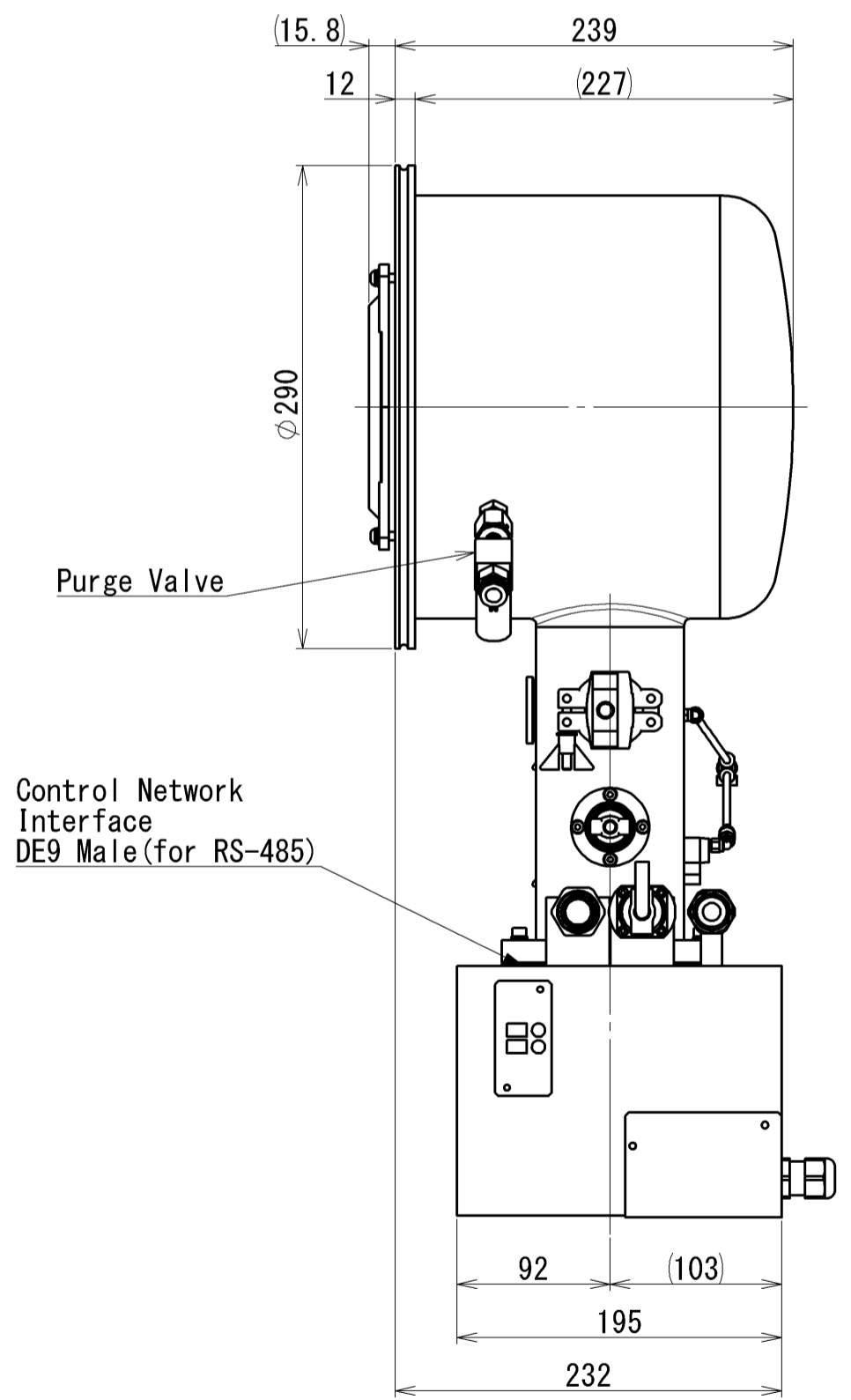
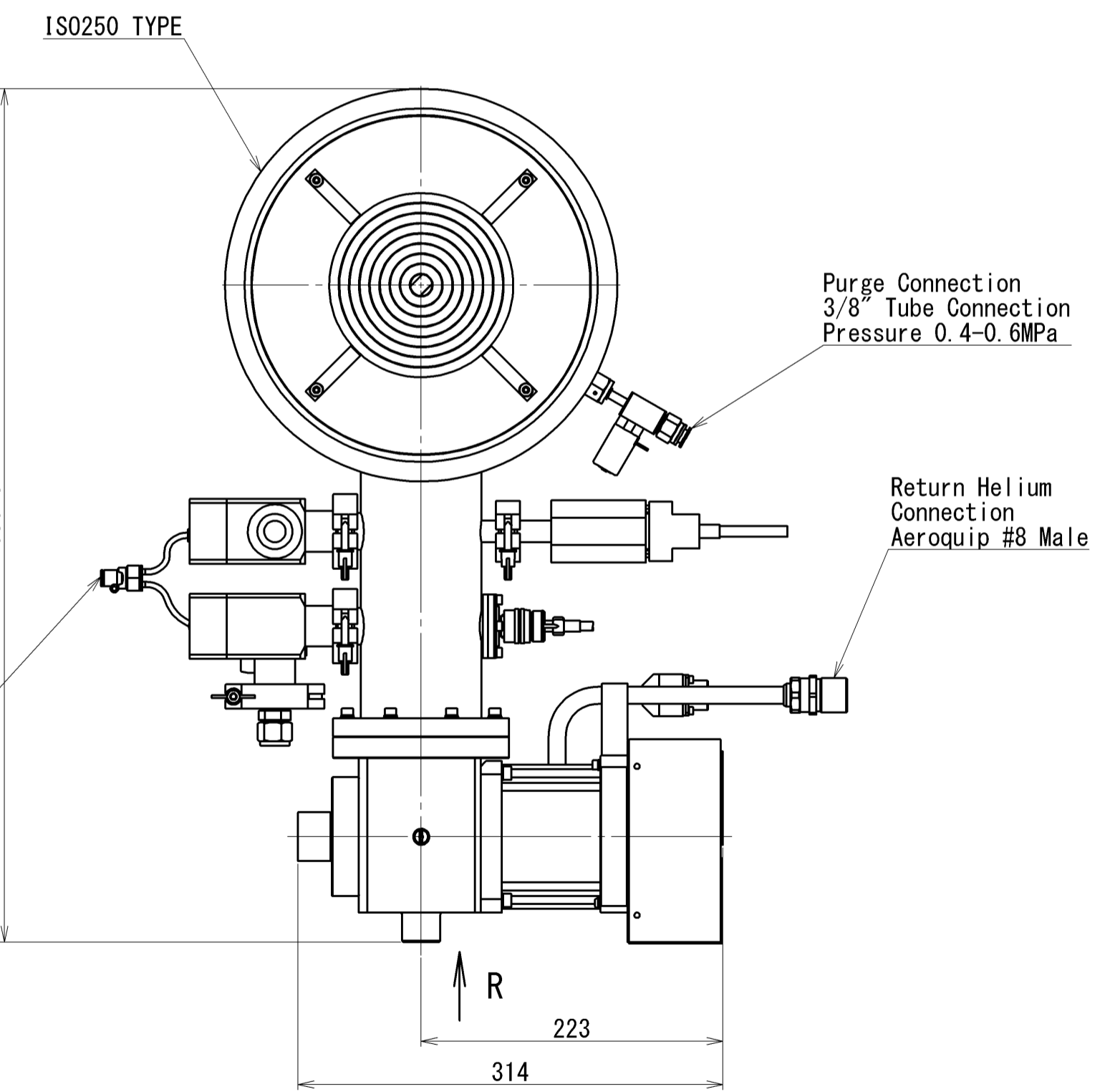
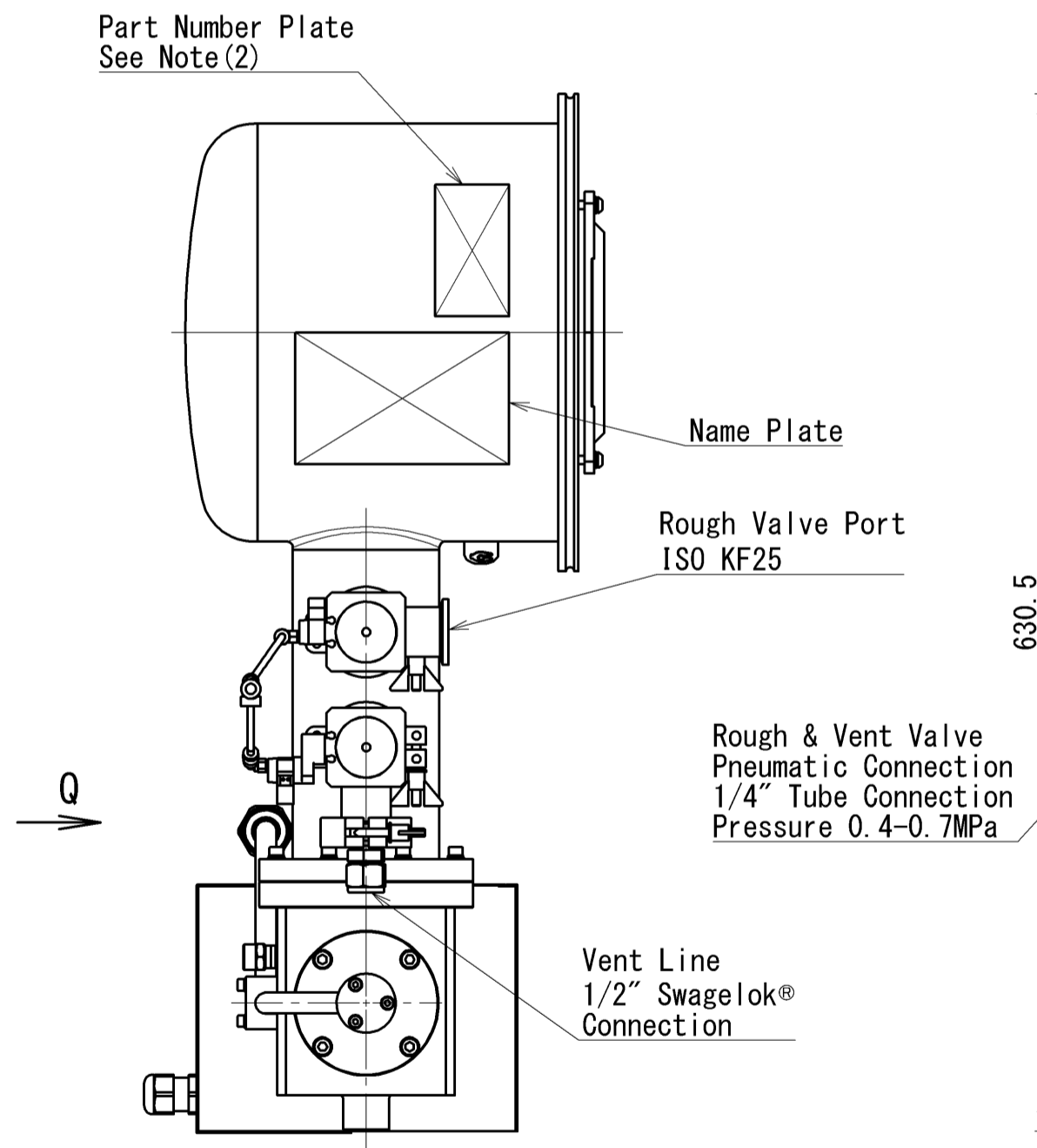

METRIC

SCALE	1:4	DATE	2021/07/09	Cryopump KZ-10SCLOA0B3 SHI P/N : KZ-10SCLOA0B3-0 DWG. NO.
DRAWN	T. Sakamoto	DESIGN	S. Gotanda	
INSPECTION	T. Yatsu	APPROVAL	M. Nakamura	Sumitomo Heavy Industries, Ltd. <b>RG25ZH2254AQ</b>
DESIGN CHANGE No.		DATE	2021/07/09	
BY	S. Gotanda			