



CH-160D3LT 20K CRYOCOOLER SERIES



The CH-160D3LT single-stage Gifford-McMahon Cryocooler is SHI's newest and highest-capacity 20K Cryocooler, with a first-stage capacity of 90/100 W @ 20 K (50/60 Hz).

The CH-160D3LT is ideal for a number of applications, including liquid hydrogen generation and liquefaction; clean energy technologies; and high temperature superconducting applications such as cables, fault current limiters, wind turbines, ship motors and accelerator magnets.

It is available as a complete system, along with two (2) F-70 indoor, water-cooled helium compressors and all related gas lines and power cables.

Like other cryocooler systems from SHI, the CH-160D3LT offers users high quality and proven reliability, along with a global sales, service and support network.

Features

The CH-160D3LT combines the best features of SHI's CH and RDK Cryocoolers series, including:

- Displex® pneumatic drive technology to limit the number of wear parts in the refrigerator
- Upgraded Whisper® technology for quieter operation
- Updated gas-balanced valve design to reduce torque as well as wear and tear
- New stem drive design improves efficiency and increases maintenance interval
- Novel heat exchanger designed to increase efficiency
- CE compliance

Performance Specifications

Power Supply	50 Hz	60 Hz
1st Stage Capacity	90 W @ 20 K	100 W @ 20 K
Minimum Temperature ¹	<17 K	
Cooldown Time to 20 K ¹	<30 Minutes	
Weight	31.8 kg (70 lbs.)	
Dimensions (HxD) ²	530 x ø241 mm (20.9 x ø9.5 in.)	
Maintenance	13,000 Hours	
Regulatory Compliance	CE	

¹ Lowest temperature and cooldown time are for reference only.

² With standard flat warm flange. (Available in other warm flange interfaces.)

Specifications subject to change without notice.

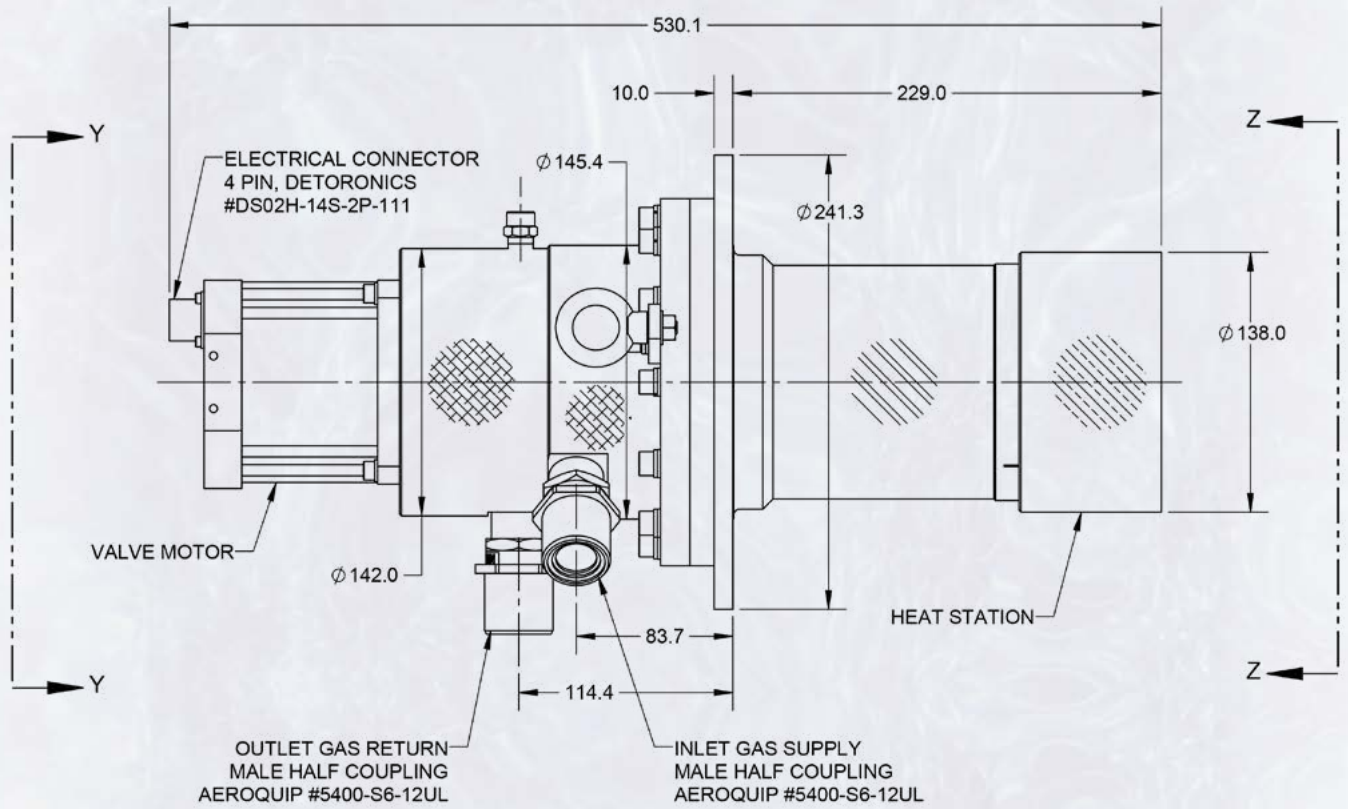

MOUNTING FLANGE HOLES
 $\phi 11.10$ THRU, (8) HOLES
 EQ SPACED ON A $\phi 217.6$ B.C.

HEAT STATION MOUNTING HOLES
 (8) M10 X 1.5-6H X 15mm LG. HELI-COILS
 EQ. SPACED ON $\phi 101.6$ B.C.

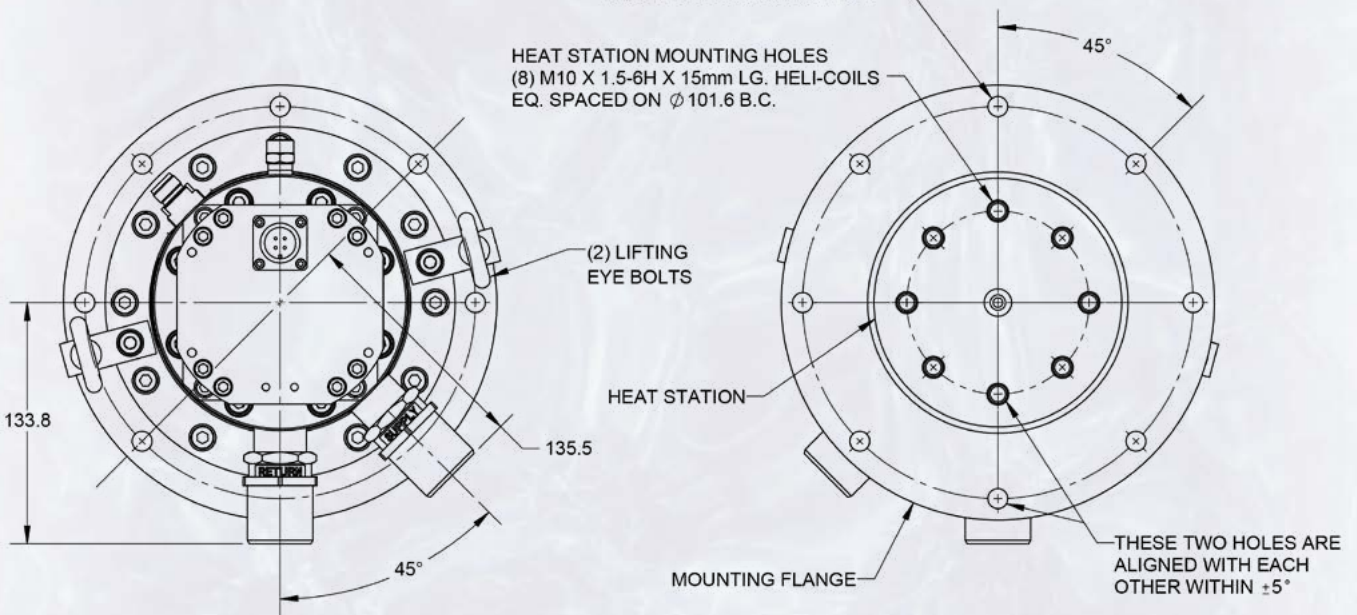

VIEW Y-Y

VIEW Z-Z